A novel acoustic test bench for evaluating underwater acoustic modems by numerical real-time simulation of the acoustic channel

Arzelies Patrick ^{1,*}, Drogou Michele ¹, Opderbecke Jan ¹, Noel Claire ², Beauchene Serge ²,
Martin Christophe ³, Lachaud Emilie ⁴, Nasr Amin ⁵

¹ IFREMER, Zone Portuaire Bregailon, BP CS20330, F-83507 La Seyne Sur Mer, France.

² Semantic TS, F-83110 Sanary Sur Mer, France.

³ DCNS Ingn Div Syst Navals Surface, F-36600 Ruelle Sur Touvre, France.

⁴ TECHNIP Innovat & Technol Ctr, F-92500 Rueil Malmaison, France.

⁵ TOTAL Explorat & Prod, F-64000 Pau, France.

* Corresponding author s: Patrick Arzelies, email address : Patrick.Arzelies@ifremer.fr ; Claire Noel, email address : noel@semantic-ts.fr

Abstract :

This paper deals with underwater acoustic communication, and especially details an innovative approach for off the shelves existing modems performances evaluation. The originality is to be able to predict the operational performances of existing acoustic modems in a real complex situation, without sea trials.

The principle is to use of two separate large basins, in order to avoid direct acoustic coupling between transmitting and receiving modems, and reduce unwanted reflections (Fig.1).

I. INTRODUCTION

This paper aims at contributing to a crucial preoccupation: on the basis of a complex underwater context (depth, geometry, distance between transmitter and receiver, ambient noise, sound velocity profile ...), when underwater acoustic data transmission is needed, which one of the COTS underwater "modem" will suit ?

An intensive bibliography on underwater acoustic communication and a complete evaluation of the situation gave the answer : it is not possible to predict at sea operational performances, starting only on existing datasheets, generally evasive concerning modulating and coding technology, and often very optimistic and not really rigorous [1]

In this paper we propose an innovating approach to evaluate operational performances of existing underwater acoustic communication systems, based on on-shore wet tests with innovating real time underwater acoustic propagation modeling.

PA

March 20, 2015

II. APPROACH

The approach was to avoid sea trials, generally expensive and difficult to reproduce because the environment is not under control. Certainly, today some "virtual" at sea test facilities are accessible, but not proprietary [2]

The approach was also to avoid intrusive intervention on hardware : no disassembly of the equipment (risky for modems integrity)

Thus the choice is : onshore test in large tanks, underwater acoustic coupling for transmitting and receiving signals, underwater sound real time propagation model RAYSON developed by Semantic-TS (cited by Paul Etter in [3])



Fig. 1. Testing resources committed

The signal emitted by the transmitting modem is acoustically recovered in the dock, then injected into the real time propagation simulator, which delivers the signal transformed by propagation. This signal is acoustically sent to the receiving modem in the second tank (Fig. 2)

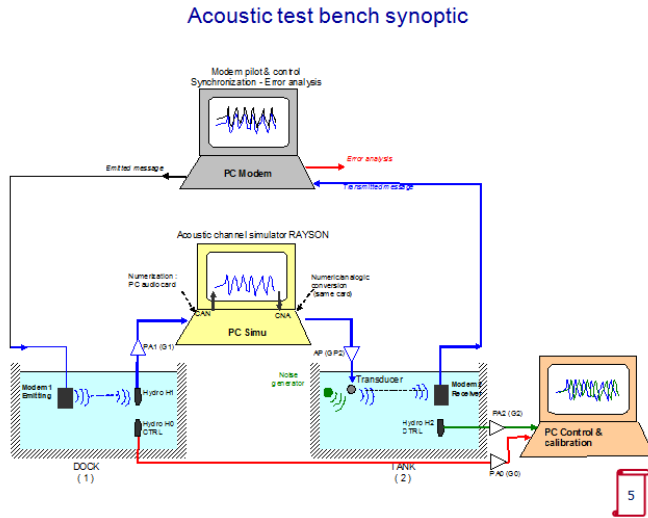

Fig. 2. Test bench synoptic

Several challenges have been solved :

A. Acoustic coupling validity

The principle of the acoustic coupling is to sample the signal transmitted in the dock and transmit this signal in the tank with the minimum distortion. The equipment used must be compatible with the frequency bandwidth modem used. Parasite reflections coming from surface, bottom, walls reflections must be minimized (unwanted reflections are 20 dB below useful transmit signal - Fig.3).

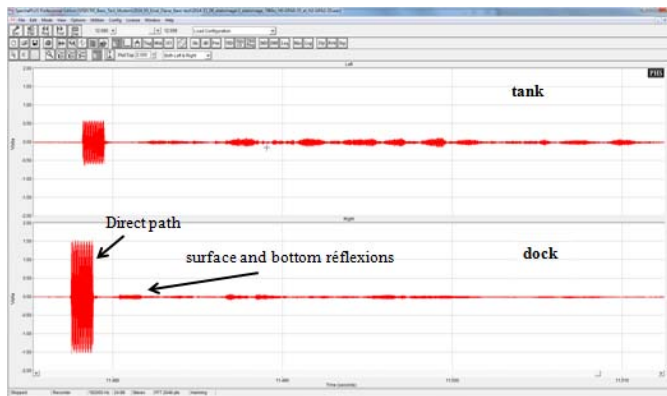

Fig. 3. useful and parasit signal level

B. Transferring signals between dock and tank

The challenge is to transmit over a length of 45 m through a buried pipe 25 m length (because of trucks traffic): the signal emitted by the transmitter modem in the dock, the signal to be re-injected into the basin, and the data received by the receiving modem. Parasite electromagnetic coupling is severely fought.

C. Test bench acoustic calibration

The operational situation is : one modem transmitting at full power a source level SL_{em} , and another modem which receives the signal affected by propagation losses. The test bench must be representative of this situation. As in our tests the transmitting modem works at reduced source level ($SL_{real} = SL_{em} - 20 \text{ dB}$) in order to avoid hydrophone saturation, thus the whole chain gain must be adjusted to insure the source level of the signal re-injected in the tank equal to $SL_{real} + 20 \text{ dB}$ - propagation losses (Fig.4)

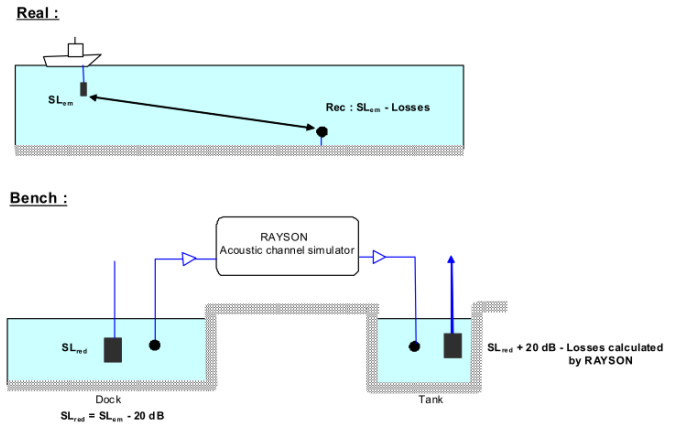

Fig. 4. acoustic test bench calibration

Calibration is done before each experiment. Noise is measured before each experiment, in order to know the environmental conditions.

D. Acoustic monitoring

The acoustic control chain allows monitoring and comparison of the acoustic environment in both basin and dock. The acoustic control chain consists in a digital/analog acquisition card (resolution: 24 bits / sampling frequency 192 kHz), a powerful dual channel spectrum analyzer software, two preamplified hydrophones (bandwidth 100 Hz - 300kHz) and two preamplifiers. The dual channel spectrum analyzer provides real time spectral analysis as well as recording, playback and post processing capabilities. It can display :

1) *times series* : This view displays the raw digitized audio data and is similar to an oscilloscope display with the amplitude shown on the vertical axis and time on the horizontal axis,

2) *Spectrum* : This view is a 2 dimensional plot of the spectrum. The horizontal axis shows the frequency in Hertz (Hz). The vertical axis shows the amplitude of each frequency line,

3) *Spectrogram* : This view displays the spectral data over time with the amplitude shown in color and

4) *3D Surface* : This display is a perspective view of the spectral data over time. Frequency is shown on the X-axis and time on the Y-axis.

IV. REAL TIME UNDERWATER ACOUSTIC PROPAGATION MODEL RAYSON

In this acoustic test bench we use a simulation tool, called RAYSON, to model in real time underwater acoustic communication over time-varying channels and taking into account Doppler effect due to sensors movements. Physical parameters characterize time varying channels by integration of static parameters (kind and form of sea surface or sea bed) and variable ones (celerity, receiver moves).

Underwater Acoustic (UWA) channels are characterized by multipath phenomenon whose characteristics are time-varying. This variation of speed is partly due to the medium (change of celerity, nature of the sea-bed, form of surface) but also to the instruments (movements, immersion depth...). The performance evaluation of a transmission in simulation thus requires taking into account variability in order to estimate the robustness of treatments.

Whatever the degree of modeling could be, simulation cannot perfectly represent the reality (due to insufficient knowledge of the environment, erroneous modeling...). However, this tool can be of great utility in the preparation of sea trials (optimization of instrumental positions, comprehension of global phenomena, modem test bench...) as the conception of acoustic links by the evaluation of the impact of environment on transmitted signals.

The author's contribution is first based on the development of software in order to evaluate performances of underwater acoustic communication, then on its use in a novel acoustic test bench for evaluating underwater acoustic modems.

RAYSON is a real time acoustic propagation model based on rays method and able to take into account various realistic environments. It enables to take into account source receiver directivity and receiver trajectory. The impulse response is determined by the preliminary definition of configuration of transmission (celerity, nature and form of surface and sea bed, movements of the transmitter and the receiver...) and is then calculated and interpolated on the receiver trajectory point by knowing it in each point of the receiving area. In situ signals and measured noise could also be integrated on any part of the link. The program also has a procedure of Monte-Carlo type that allows in batch mode, automatic and systematic statistical numerical simulations that means determination of ray characteristics and their intensity for a set of speed profiles, moving surfaces, or unknown bottoms whose description files are present in a directory.

This tool is suitable for testing all configurations (provided rays propagation is available) and is able to deal with time variant impulse response. Performances of acoustic link could be then evaluated. This tool is particularly useful to design acoustic link, especially in defining necessary power and frequency band, and to evaluate environment impact on the transmission.

The different functionalities of RAYSON and the real time method developed to take into account Doppler effect in the propagating signal computation are presented in [4], [5].

V. SCHEDULED TESTS

We have chosen to first test simple configurations (for this feasibility phase) :

A. Single acoustic ray path

Fixed position (without Doppler). The aim is to measure the distance where modem doesn't receive anymore. (fig 5)

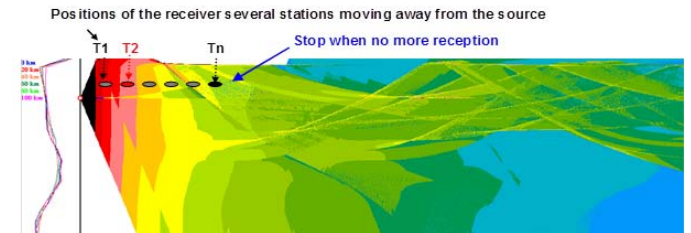

Fig. 5. Only one path (the others are artificially deleted)

B. Multipaths

Fixed position : test of two adjacent positions for which one is the result of constructive and coherent summation, the other the result of destructive coherent summation (fig 6)

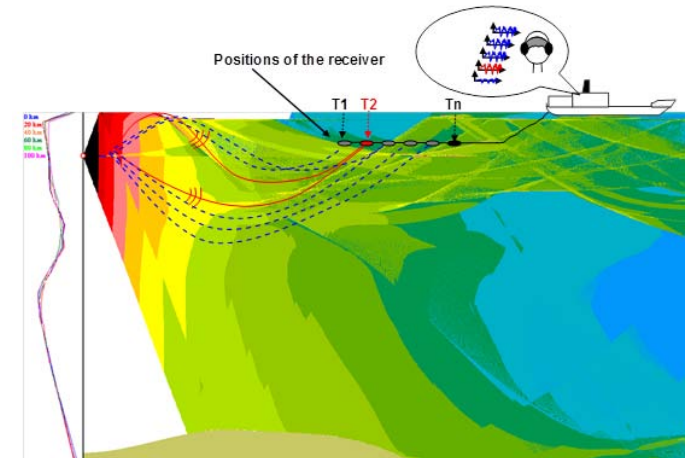

Fig. 6. Multi-paths impact, without noise and Doppler. Several stations are chosen, corresponding to places with destructive and constructive interferences, with two raypaths.

C. Doppler impact

(Fig.7)

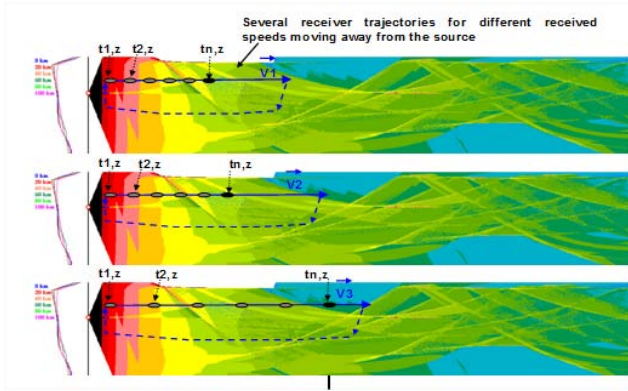

Fig. 7. Doppler effect, in case of mono-path propagation, for several speeds of the receiver.

VI. RESULTS

One pair of modems (60 kHz center frequency) has been extensively tested on the bench, and compared with previous at sea trials. Interesting coherent results were obtained. Whole test has been done in high acoustic noise situation.

A. Single ray path fixed position

Without noise, i.e. with ambient noise (the minimum ambient acoustic noise level in the test tank is near sea state 6 because of the environment (vessels at quay, port area, heavy weather conditions with intense rain)

Test bench with propagation simulation from 200 to 1100 m in 100 m step : Acoustic Range Limit of 900 m.

This is coherent with at sea experiments in the same acoustic conditions.

B. Single ray path test with noise injection in the tank

For each fixed point (From 200 to 800 m in steps of 200 m), acoustic noise is increased up to the limit of detection. The limit is obtained for SNR between 0 and 3 dB.

Conclusion: ability of the bench to test the limits of range with and without noise.

C. Multipaths fixed position

For each fixed point (From 200 to 500 m in steps of 100 m) we test two adjacent positions for which one is the result of constructive coherent summation and the other the result of destructive coherent summation.

Conclusion: highlighting of a (tiny) area where there is no transmission at all (destructive coherent summation). Same kind of situation has been observed at sea, not exactly in the same conditions. To be investigated.

D. Doppler

Doppler tests were not significant for speed above 0.2 m/s, due to a current dysfunction identified in RAYSON software. This does not challenge the test bench feasibility, but some work has to be spent on RAYSON to modify it and to re-test it.

E. Complexe case

Shallow water - Processed without Doppler.

VII. CONCLUSION

This paper does not seek to provide a complete answer to the problem of underwater acoustic communication. Some physical phenomena are currently not correctly taken into account (Doppler for example). But the bench is evolving. The aim is to make a contribution to the building of underwater communication. One advantage of the bench is to offer possibility of separately analyzing each underwater acoustic propagation parameter, because the whole environment is mastered.

The objective is not to say whether a modem is good or bad. The aim is to predict the operational performances in a given use case configuration. Three pairs of others modems will soon be tested, in order to settle operational use on IFREMER underwater vehicles. Offshore oil underwater intervention expecting our expertise, other investigations are quickly planned.

REFERENCES

- [1] Arthur B. Baggeroer, " An Overview of Acoustic Communications from 2000 - 2012, Underwater Communications Conference. NATO CMRE, 12-14 sep 2012.
- [2] Tommaso Melodia, Hovannes Kulhandjian, Li-Chung Kuo, Emre Can Demircos " Mobile Ad Hoc Networking: Cutting Edge Directions - chap 23 Advances in Underwater Acoustic Networking", John Wiley and Sons 2013.
- [3] Paul C. Etter "Advanced Applications for Underwater Acoustic Modeling", Hindawi Publishing Corporation, Advances in Acoustics and Vibration, volume 2012.
- [4] Christophe Viala, Claire Noel, Gerard Lapierre, a real time underwater communication simulator and performance estimator, Proceedings of the Seventh 7th French workshop on Underwater Acoustics, 7e JASM, October 19-20 2004. 7e Journes d'Acoustique Sous-Marine.
- [5] Gerard LAPIERRE, Christine LE BRUN, Christophe VIALA, TALISMAN : An innovative tool using time varying channel model to evaluate performances of an acoustic link, Proceedings of OCEANS, 2001. MTS/IEEE Conference. 5-8 Nov 2001.