

Proceedings of the Eighth
EuroGOOS International Conference

3-5 October 2017, Bergen, Norway



OPERATIONAL OCEANOGRAPHY

Serving Sustainable Marine Development

Edited by:

Edited by: Erik Buch, Vicente Fernández, Dina Eparkhina,
Patrick Gorringe and Glenn Nolan

NOVEL, MULTI-PLATFORM ACOUSTIC AND OPTICAL SENSORS AND DATA SERVICES DEVELOPED IN THE NEXOS PROJECT

L. Golmen⁽¹⁾, E. Delory⁽²⁾, O. Zielinski⁽³⁾, J. del Rio⁽⁴⁾, K. Kvalsund⁽⁵⁾, J. Pearlman⁽⁶⁾,
L. de Swart⁽⁷⁾, L. Delauney⁽⁸⁾, M. Rieke⁽⁹⁾ and S. Østerhus⁽¹⁰⁾

⁽¹⁾ Norwegian Institute for Water Research, NIVA, Bergen, Norway, Lars.golmen@niva.no

⁽²⁾ Plataforma Oceánica de Canarias, PLOCAN, Telde, Spain

⁽³⁾ Carl von Ossietzky Universität, UNOL, Oldenburg, Germany

⁽⁴⁾ Universitat Politècnica de Catalunya, UPC, Barcelona, Spain

⁽⁵⁾ Runde environmental centre, REC, Runde, Norway

⁽⁶⁾ IEEE, Seattle, WA, USA

⁽⁷⁾ ECORYS, Rotterdam, Netherlands

⁽⁸⁾ IFREMER, Brest, France

⁽⁹⁾ 52°North, Münster, Germany

⁽¹⁰⁾ UNI Research, Bergen, Norway

Abstract

The European Union FP7 project “Next generation, Cost- effective, Compact, Multifunctional Web Enabled Ocean Sensor Systems Empowering Marine, Maritime and Fisheries Management” (NeXOS, 2013-2017) focused on innovative approaches for two classes of insitu observations, acoustic and optical. Two types of innovative passive acoustic sensors were developed - one having a single detector with increased dynamic range and internal processing to reduce communication requirements and the other having an array of four such sensors providing directional capabilities. The optical sensors developed were Matrix fluorescence sensors, a minifluo fluorescence sensor, flow-through cavity absorption sensors, and sensors for monitoring the carbon system. Additionally, optical sensors for chlorophyll-a and dissolved oxygen were adapted for use in fisheries. The sensors were modified to enable plug-and-play capabilities on the basis of the Open Geospatial Consortium (OGC) PUCK protocol embedded in the internal software of the sensor. This protocol ensures that measured data are accompanied by metadata describing the sensor and its history. The OGC Sensor Web Enablement (SWE) and the Sensor Observation Service (SOS) web server make data from the NeXOS sensors available in real-time to the end-users. The final demonstrations took place during summer of 2017 in the Northeast Atlantic, Central Atlantic and the Mediterranean. This manuscript presents the main outcomes of the project.

Keywords: Optical sensor, acoustic sensor, SEISI, Sensor web enablement, NeXOS

1. Introduction

Two main sensing techniques were implemented in the European Union FP7 project “Next generation, Cost- effective, Compact, Multifunctional Web Enabled Ocean Sensor Systems Empowering Marine, Maritime and Fisheries Management” (NeXOS, 2013-2017), reported on here. The aims of the NeXOS project were to provide innovative and practical solutions to some of the challenges of comprehensive ocean observations such as the need to reduce power requirements, reduce data communication bandwidth requirements, introduce new frameworks for interoperability and provide operators and users with improved information.

NeXOS developed two types of innovative sensors – based on optical and acoustic measurement principles, respectively. See Table I for an overview. The optical sensors were of three types: Matrix fluorescence, *in situ* sensors (O_1), Flow-through cavity absorption sensors (O_2), and sensors for monitoring the carbon cycle (O_3), (Pearlman and Zielinski 2017). One series of O_1 sensors applied the distinct wavelengths combination for excitation and emission to measure in a Matrix Configuration. The second series were for measurements by two single optical channels using ultraviolet light range for excitation. The target parameters included fluorescent dissolved organic matter (FDOM) peaks, Chlorophyll-a, Naphthalene, Phenanthrene and Fluorene. The O_2 type flow-through sensors were the semi-automated PSICAM and the fully automated and compact HyAbSv/2, and the flow-through and submersible OSCAR-G2. The O_3 sensors were different combinations for measuring the carbon system parameters pCO_2 , pH and total alkalinity in a flow-through setup.

Two compact, passive acoustic sensors were developed, A1 having a single detector with increased dynamic range and A2, an array of such sensors providing directional capabilities (Delory *et al.* 2014). A2 is a series of individual volumetric hydrophones, enabling real-time measurement of underwater noise and of several soundscape sources, consisting of an array of 4 digital hydrophones with Ethernet interface and a master unit for data processing. Besides this, an antifouling system was developed to fit a type of optical sensor, also adaptive to underwater cameras (Delauney *et al.* 2015). With respect to fisheries management, new, very sturdy, small size and very-low cost sensors were developed specifically for fishing vessels. These are chlorophyll and oxygen sensors for installation on fishing nets. The sensors are defined as an EAF sensor system (Ecosystem Approach to Fisheries).

Table I. Sensors developed in the NeXOS project, with some target platforms.

SENSOR TECHNOLOGY		SENSOR TYPE	
Optical		O1 Matrix-fluorescence	
		O2 Hyperspectral	
		O3 Carbon	
Passive Acoustics		A1 Preprocessed	
		A2 Real-time	
RECOPECA/EAF		EAF/Chlorophyll	
		EAF/Oxygen	
CROSS CUTTING TECHNOLOGIES			
Smart Sensor Interface – OGC PUCK + SWE		Bio-fouling prevention	
TARGET PLATFORMS			
Gliders	Drifters/profilers	Cable Observatories	Ferries
Trawlers	Nets & Lines	Other leisure	Stand alone

All developments in NeXOS followed these requirements: High reliability; High resolution of measurements; Robustness; Low energy consumption; Reduced size and Affordable cost. The selected platforms for demonstrating the sensors were gliders, voluntary observing ships (FerryBox), a seafloor cabled observatory, an autonomous surface vessel (Sailbuoy) and fishing vessels.

In the integration work, the sensors were modified to enable plug-and-play capabilities based on the Open Geospatial Consortium (OGC) PUCK protocol embedded in the internal software. This protocol ensures that measured data are accompanied by metadata describing the sensor and its history. The OGC Sensor Web Enablement (SWE) and the Sensor Observation Service (SOS) web server make data from the NeXOS sensors available in real-time by the end-users.

1.1 Market and TRL study

Manufacturing of sensors for operational use is governed in part by maturity of the sensor and its technology. This is indicated by the technology readiness of the sensors according to a scale “Technological readiness level” (TRL; Sadin 1989) which assigns a level of 6-7 for sensors demonstrated in development, 8 for sensors demonstrated in prototype operations and 9 for operational systems. NeXOS did an assessment of TRL for its sensors. The levels ranged from 2-5 at the beginning of developments, with level 7-8 at the end of the project. This means close to market, but still with some issues to be resolved. The main focus of the NeXOS market study was to assess the market for optical sensors, passive acoustic sensors and the Ecosystem Approach to Fisheries (EAF) sensor system. The value chain of the market was drawn to depict the distinct activities that add value to science and maritime observation activities. The activities on the main branch of the value chain include sensor manufacturing, sensor developing and integrating into platforms as well as adapting the sensors to the needs of the observations, operating them, analyzing the collected data and exploiting the results of the observations.

The main and most promising market segments for marine sensor activities were identified with 3 perspectives of sensor use that actually drive the user requirements for sensors. These perspectives are: i) research, ii) industry and iii) research and development. The growth expectations were examined of the different market segments beyond the traditional, long-standing markets of Europe and North America, looking into the developments on a global scale. Main market segments, which make use of marine sensors include: Industrial water quality; Research, Offshore oil & gas; Environmental monitoring; Ocean renewable energy, Port security, Aquaculture & Fisheries and Deep sea mining.

1.2 Sensor interfacing and sensor web enablement

NeXOS recognized that helping users with data access and data visualization would stimulate adoption and provide practical benefits to the ocean observation and industry communities. At the sensor system level, the Smart Electronic Interface for Sensors and Instruments (SEISI)- supports both a pull-based data access interface (i.e. based on the SOS standard) as well as a push-mechanism for delivering data into observation databases. To provide these functions, non-SEISI systems needed to be integrated into the NeXOS Sensor Web architecture through dedicated Sensor Bridges. As part of this, NeXOS provided guidance on how to apply Sensor Web technology in oceanography (del Rio et al. 2014).

The main objective of the SEISI is to have an interface capable of providing a standard communication interface for non-standard sensors with analogue output and instruments with analogue or digital output (Fig. 1). SEISI is a set of standards and functionalities to enable web-based sharing, discovery, exchange and processing of sensor observations, and operation of sensor systems. NeXOS worked to minimize the integration time with different types of observing systems and platforms, and to maximize the interoperability with upper communication layers. Internet protocols were used for propagating data to the user’s Sensor Web Level, by SWE standards. SensorML files with instrument metadata were installed in the instruments, to secure the correct dissemination of data and track-record the applications.

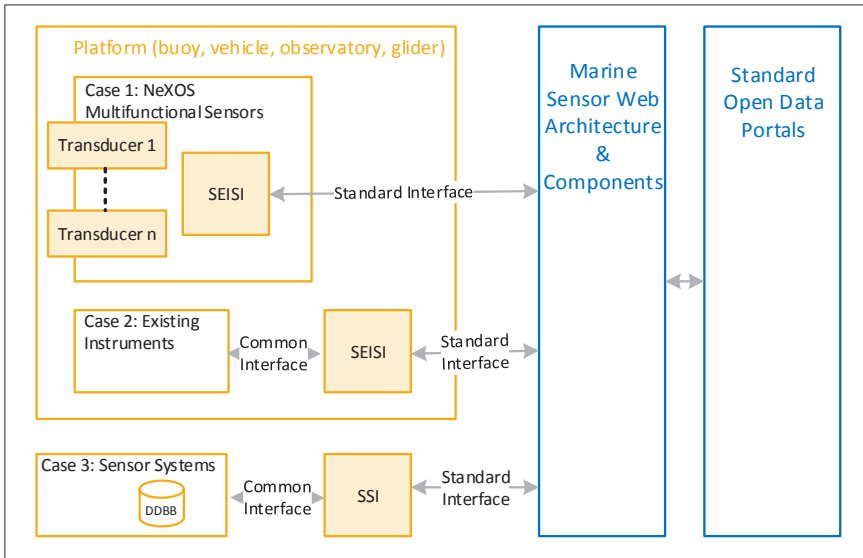

Fig. 1. Smart Electronic Interface for Sensors and Instruments (SEISI).

The SEISI reads the SensorML, a sensor metadata, from PUCK payloads in instruments, actuators, or platforms to automatically configure the onboard services (enable/disable SEISI input interface, or enable/disable output interface Ethernet, RS232). This was illustrated using a FerryBox scenario. In NeXOS, all sensors had a PUCK interface.

2. Validation and demonstration

Validation or verification was performed to document functionality, operability and data quality of a sensor on a specific platform. The sensor systems were then functionally demonstrated at sea under real oceanic conditions, over periods of several weeks. The final demonstrations took place during the summer of 2017 in areas of the Northeast Atlantic, the Central Atlantic and the Mediterranean. Each mission was given a Mission ID (Table II). The acoustic sensors were demonstrated on an underwater glider, on a wave glider, an underwater observatory and on a beacon. The optical sensors were demonstrated on a glider, a float, a buoy and in a FerryBox system. The EAF sensors were installed on fishing gear belonging to fishing vessels in Norway, France and Italy, respectively. An important part of the demonstrations was to document data flowing continuously from the sensors to the internet data viewer, and including the fixed sensor metadata provided in the embedded SensorML files. The functionality of the SOS server and the real-time data viewer was also demonstrated (Fig. 2). Here, multiple data time series and profiles can be selected. This service also includes a map tracing facility, and a data file download option.

Table II. The Platform/sensor pairing in NeXOS, according to the demonstration plan.

MATRIX OF PLATFORMS AND SENSORS					
SENSOR	PLATFORM NAME	PLATFORM OWNER	TYPE OF PLATFORM	SENSOR TO VALIDATE	TARGET DEMO MISSION
A1.4	ESTOCTB	PLOCAN	Stand Alone Mooring	A1	Can4
A1.1 / 01.4	Wave Glider	PLOCAN	Surface Glider	A1 / 01 matrixFlu UV	Can1 / Can2
A1.3	Provov	NKE	Profiler	A1	Can3
A1.2 / 01- Mini	Sea Explorer	ALSEAMAR	Glider	A1 / 01 MiniFluo	Nor2 / Nor1
03.2	Sail Buoy	CMR	Surface Vessel	03 Cbon2-sv	Nor3
03.1 / 03.4	Ferrybox	HZG/NIVA	Vessel	03 CBon2-fb / 03-Cbon3-fb	∫ Nor5
02.1 / 01.2 / 01.3	Ferrybox	HZG	Vessel	02 HyABS / 01 matrixFlu VIS/UV	∫ Nor4
EAF.3 / EAF.5	Fishing Vessel	REC	Vessel	EAF-3 DO / EAF-5 Fluo	Nor6
EAF.4 / EAF.6	Fos/Foos Vessel	CNR	Vessel	EAF-4 DO / EAF-6 Fluo	Med3
A2.1	Obsea	UPC	Cabled Observatory	A2	Med2
A1.e	Beacon	CNR	Moored buoy	A1	Med1
T3.2-	Biofouling test station	IFREMER	Basin/pool	Antifouling system	N/A

The NeXOS project successfully provided 8 new cost-effective sensor systems and products like an open-source SWE framework, a SML Editor, an Internet viewer and SOS services. This enables an open, end-to-end interoperability framework, with data flow from sensor to services and users. The firmware code for embedded processing (acoustics) is open-source, also like the code for plug and play between sensors and platforms. The outcomes should become beneficial to many users and earth observing Communities, from EMSO to GOOS/EuroGOOS and the GEOSS.

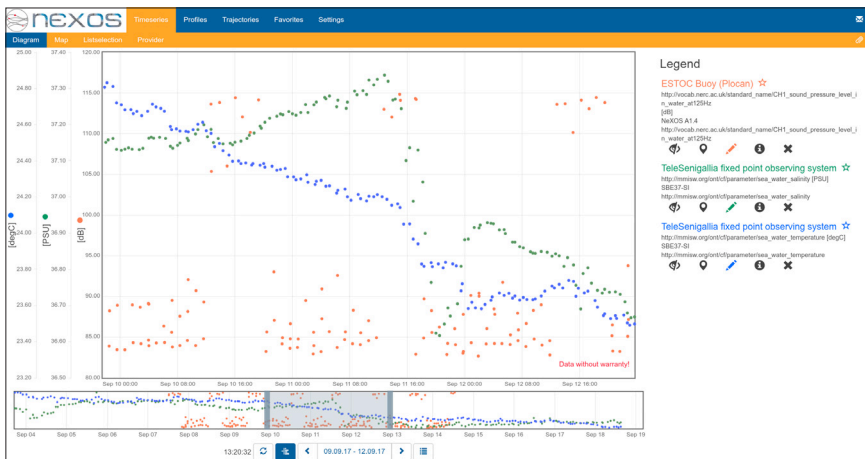

Fig. 2. Example of a data presentation from the SWE user front end viewer developed by 52oN. In this case, data from the ESTOC buoy by Plocan: sea temperature (blue dots), salinity (green dots) and sound level (orange dots).

Acknowledgements

The work reported here has been supported by the European Commission's FP7 research and innovation program under grant number 614102. We acknowledge the support from Statoil and Havila shipping for providing access to their offshore field and their vessels, respectively.

References

Delauney, L., K. Boukerma, K. Bucas, J-Y. Coail, M. Debeaumont, B. Forest, C. Garello, G. Guyader1, Y. Le Bras, M. Peleau and E. Rinnert. (2015). Biofouling protection by electro-chlorination on optical windows for oceanographic sensors and imaging devices OCEANS 2015 – Genova. ITALY, MAY 18-21, 2015, Pages 1-10.

Delory, E., D. Toma, J. Del Rio, P. Ruiz, L.Corradino, P. Brault and F. Fiquet. (2014). NeXOS objectives in multi-platform underwater passive acoustics. <http://www.uaconferences.org/index.php/component/contentbuilder/details/5/378/underwater-acoustics-conferences-unmanned-vehicles-auv,-usv-and-gliders-for-underwater-acoustic-surveillance-and-monitoring?Itemid=214>.

del Río, J., D. Mihai Toma, T.C. O'Reilly, A. Bröring, D.R. Dana, F. Bache, K.L. Headley, A. Manuel-Lazaro and D.R. Edgington. (2014). "Standards-Based Plug & Work for Instruments in Ocean Observing Systems," *Oceanic Engineering, IEEE Journal of*, vol.39, no.3, pp.430,443, July 2014. <http://dx.doi.org/10.1109/OCEANS-Genova.2015.7271715> <http://archimer.ifremer.fr/doc/00349/45998/>

Pearlman, J. and O. Zielinski. (2017). A new generation of optical systems for ocean monitoring. Matrix fluorescence for multifunctional ocean sensing. *Sea Technology*, February 2017, 30-33

Sadin, S., F. Povinelli and R. Rosen (1989). NASA technology push towards future space mission systems. In: Space and Humanity Conference Bangalore, India, Selected Proceedings of the 39th International Astronautical Federation Congress, *Acta Astronautica*, vol. 20, pp 73-77, 1989.